

ZS-6122CS
GP-IB Adapter

User's Manual

Ver.1.0



Zip Code: 183-0027

2-13-37, Honmachi, Fuchu, Tokyo, Japan

TEL : +81-(0)42-364-2126

FAX : +81-(0)42-364-0067

URL <http://www.zenisu.co.jp/>

◆ Table of contents ◆

1.Outline	3
2.Fearture	3
3.Specification	3
4.Signal and Switch	4
5.Appearance	9
6.Example for usage	10
7.Warranty	11

1. Outline

ZS-6122CP is a GP-IB adapter that can control the input and output of parallel signals up to 4 bytes with the GP-IB interface. Parallel signal can be set to input or output with each byte by DIP switch.

Using this unit makes it easy to control and transfer data of input / output interface devices such as BCD parallel signals and binary signals by GP-IB.

There are 2 types of model as below.

- (1) ZS-6122CS It is a unit that incorporates ZS-6122CP and power supply in a small case.
- (2) ZS-6122CP Printed circuit board type.

It is easy to incorporate it into a machine with height limitation since the L shape is used for the connector that connects the I/O data and the control signal. Refer to the user's manual of ZS-6122CP for signal connection, appearance etc.

2. Feature

- 1. It has both input and output functions.
- 2. It is a small size and low price.
- 3. It is easy to incorporate with equipment.

3. Specifications

- (1) Compliant with GP-IB interface standard (IEEE Std 488-1978).

Subset of interface function: SH1,AH1,T6,L4,SR1,RL1,PP0,DC1,DT1,C0

- (2) The adapter sends the input data to the control side of the GP - IB interface in talker operation.

Number of input data: 0 to 4 bytes (Delimiter by DIP switch is fixed to EOI).

Signal level: TTL (Fan-in = 1, 10 k Ω pull-up resistor).

- (3) The adapter outputs data from the control side of the GP - IB interface in listener operation.

Number of output data: 0 to 4 bytes (Delimiter by DIP switch is optional).

Signal level: TTL (74 LS equivalent, fan-out = 10).

Model	ZS-6122CP	ZS-6122CS
Type	Printed circuit board	Built in small case
Power	+5V 0.4A	+5V 0.4A
Size	120 × 144 × 16 (H) mm	130 (W) × 150 (D) × 35 (H) mm
Weight	120g	400g
Accessory	J2 Cable 60cm x 1	J6 Cable 60cm x 1
	J4 Cable 60cm x 1	
	J3 Connector x 1	J3 Connector x 1
	FAS-5001-2101-0BF (Yamaichi)	FAS-5001-2101-0BF (Yamaichi)

4.Signal and Switch

4.1 Data connector (J3)

I/O data and control signal are connected.

I/O	SIGNAL	PIN		SIGNAL	I/O
IN OUT	D0-0	1	2	D1-0	IN OUT
	D0-1	3	4	D1-1	
	D0-2	5	6	D1-2	
	D0-3	7	8	D1-3	
	D0-4	9	10	D1-4	
	D0-5	11	12	D1-5	
	D0-6	13	14	D1-6	
	D0-7	15	16	D1-7	
	D2-0	17	18	D3-0	
	D2-1	19	20	D3-1	
	D2-2	21	22	D3-2	
	D2-3	23	24	D3-3	
	D2-4	25	26	D3-4	
	D2-5	27	28	D3-5	
	D2-6	29	30	D3-6	
D2-7	31	32	D3-7		
OUT	SPM	33	34	+5V	
OUT	REMOTE	35	36	+5V	
OUT	TLK	37	38	+5V	
IN	OUT-READY	39	40	+5V	
OUT	OUT STOROBE	41	42	GND	
IN	REQUEST	43	44	GND	
OUT	TRIGGER	45	46	GND	
OUT	CLEAR	47	48	GND	
	NC	49	50	GND	

(1) D0-0 to D3-7 are I/O data. DIP switch (SW2) is used to assign input and output.

(2) Data transfer order will be from the small port number.

(3) Byte bit No.7 (D0-7, D1-7, D2-7, D3-7) are MSB.

Type and operation of the control signal connected to the J3 data connector.

PIN	Signal	Signal		Description
		Direction	Logic	
33	SPM	OUT	N	It becomes LOW level in serial polling.
35	REMOTE	OUT	N	It becomes LOW level in remote status.
37	TLK	OUT	N	It becomes LOW level in talker.
39	OUT-READY	IN	P	It becomes HIGH level when input /output equipment can receive data from ZS-6122CS. Since this signal is pull-up +5V at 10k Ω , it can be released if control is unnecessary.
41	OUT-STROBE	OUT	P	A negative pulse is output when outputting arbitrary dummy data after all the bytes of output data are aligned. About 1 μ s or 1ms can be selected for this pulse width according to the setting of DIP switch.
43	REQUEST	IN	N	SRQ is generated at the falling edge of this signal.
45	TRIGGER	OUT	N	A negative pulse of 2 μ s is output when a GET command is received from GP-IB controller.
47	CLEAR	OUT	N	A negative pulse of 2 μ s is output when SDC command or DCL command is received from GP-IB controller.

Note) When OUT-STROBE signal is required, add 1 byte of dummy data and output it.

4.2 I/O setting switch

It is a connector for status display and switch I/O signal.

It is connected to the front panel.

PIN	Signal	I/O	Description	Lead
1	+5V	-	It connects to the anode side of the LED.	Brown
2	GND	-	It connects to one side of the make contact.	Red
3	EXT-SRQ	IN	It generates SRQ with make contact or LOW.	Orange
4	LSN	OUT	It lights the external LED in listener operation.	Yellow
5	TLK	OUT	It lights the external LED in talker operation.	Green
6	EXT-RESET	IN	It makes the initial status with make contact or LOW signal.	Blue
7	SRQ	OUT	It lights the LED that is generating the SRQ signal.	Purple

Note) RESET and SRQ also have switches mounted on the printed circuit board.

4.3 Address switch (ADRS)

The address switch has 6-bit DIP switch attached. The GP-IB address is set with switches 1 to 5, and address NO. is 0 to 30. Except No.31 in all bits ON. Bit 6 switch is invalid.

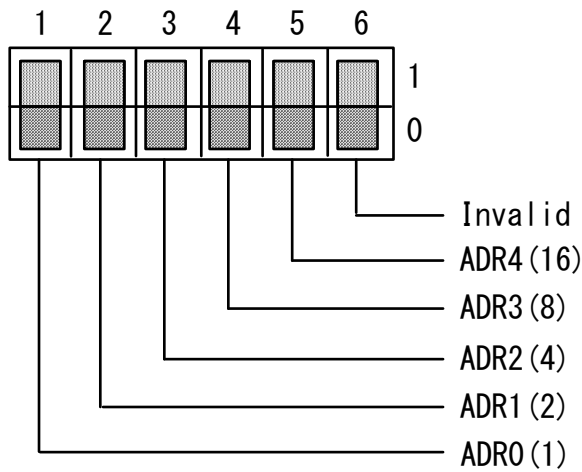

4.4 Mode switch (SW2)

This is an 8-bit DIP switch that sets the operation mode.

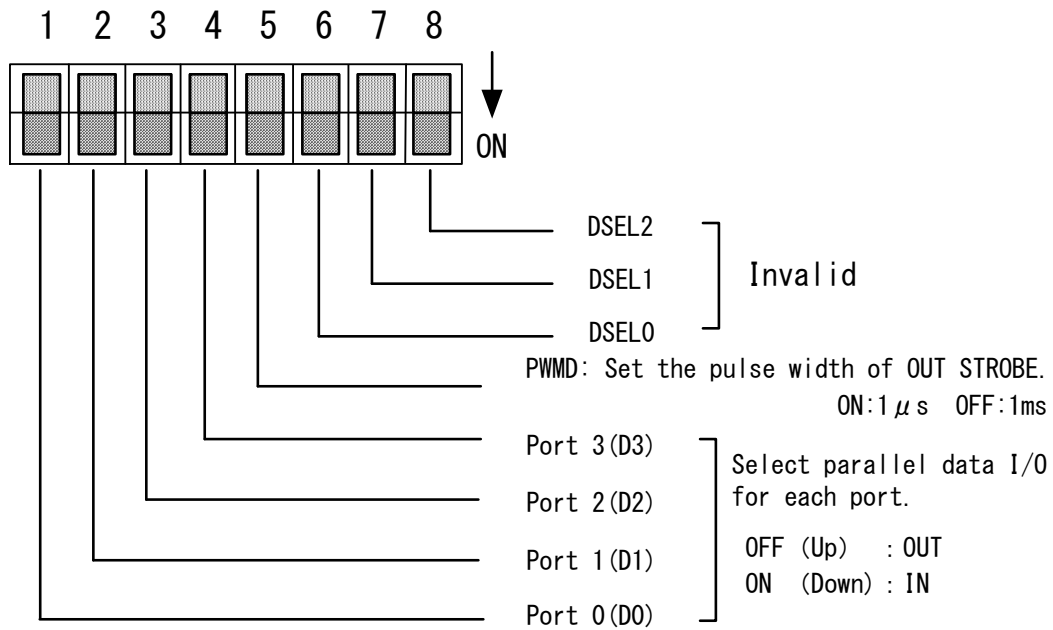

4.5 Status of serial polling

This unit also sends RQS information to inform that SRQ has occurred and DIP switch setting information of operation mode.

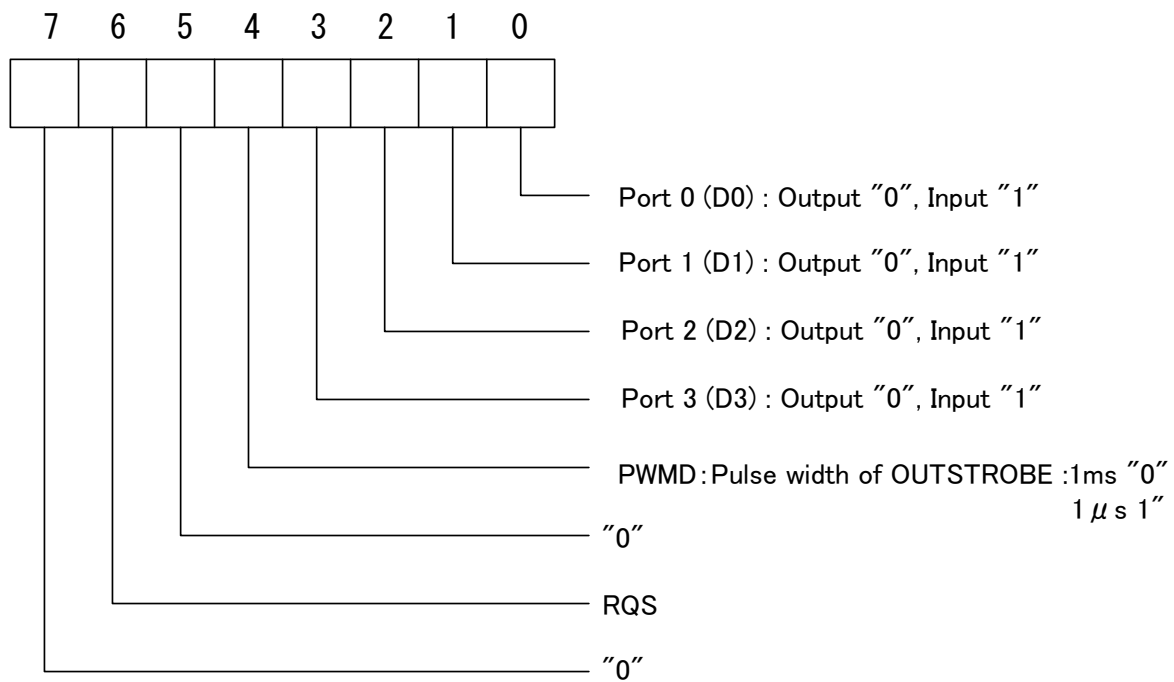

For RQS, an interrupt is generated by the REQUEST signal of pin 22 of the data connector, SRQ switch of the front panel is ON, and this bit becomes "1".

This signal goes to "0" at the end of serial polling or reset.

5. Appearance

Front side

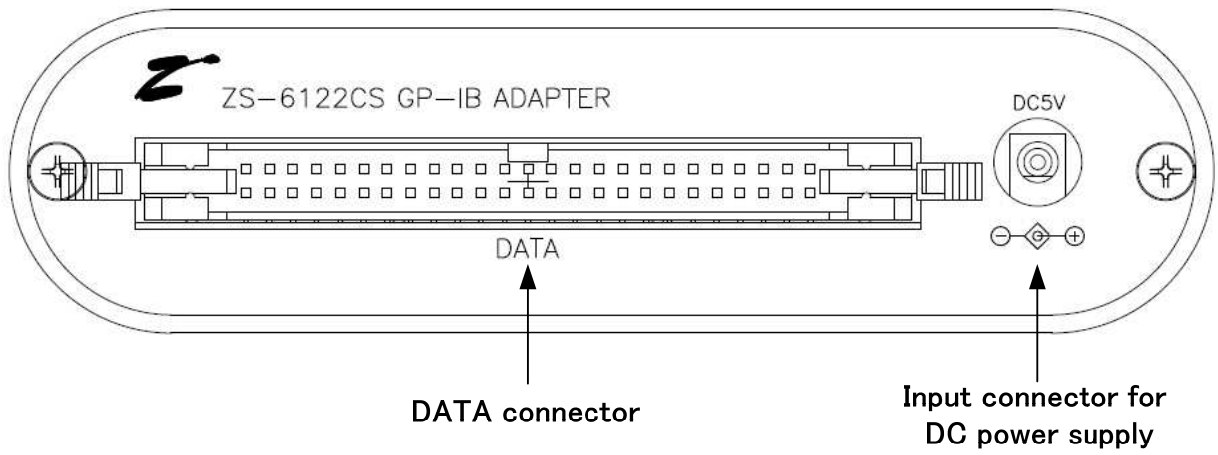

Back side

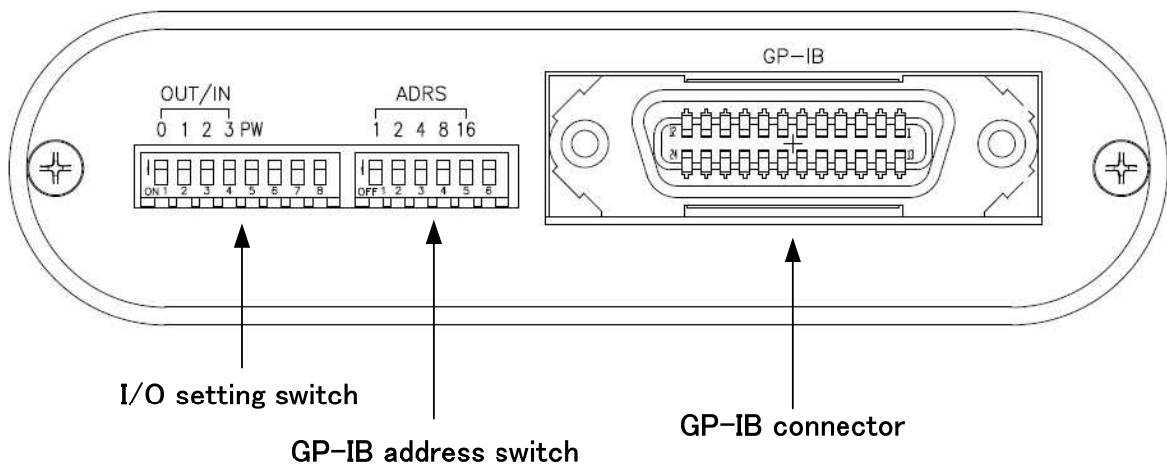

6.Example for usage

6.1 Connect to D/A converter (12bits)

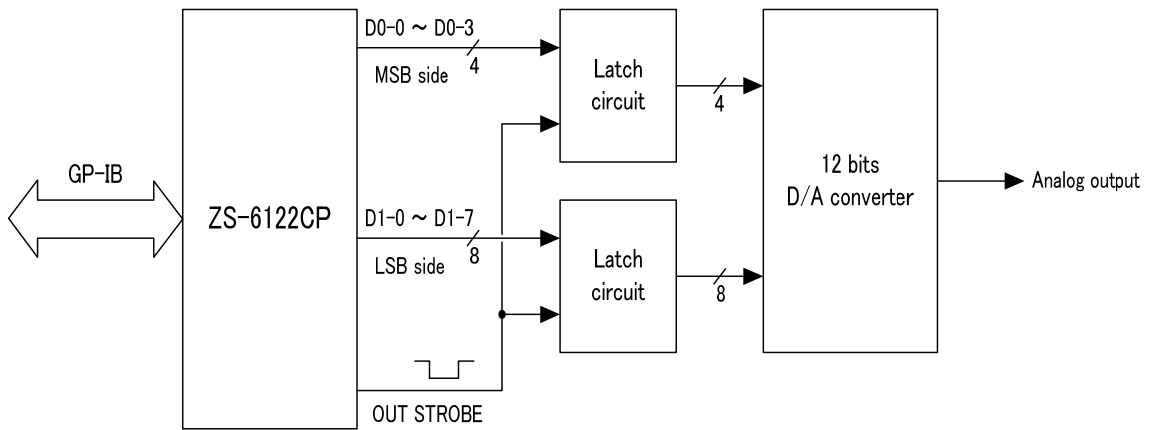

The setting of DIP switch in this case (Pulse width is 1 μ s)



6.2 Connect to A/D converter

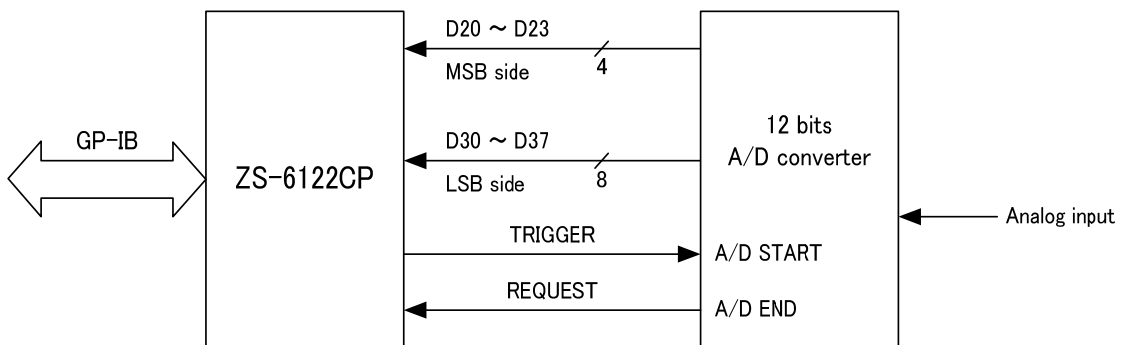

It does A/D START with TRIGGER and generate SRQ with A/D END or A/D BUSY termination. However, in case of high-speed operation where A/D operates in several tens μ s, there is a case that a method of reading data immediately after A/D START may be used without using SRQ.

(In case of address 16)

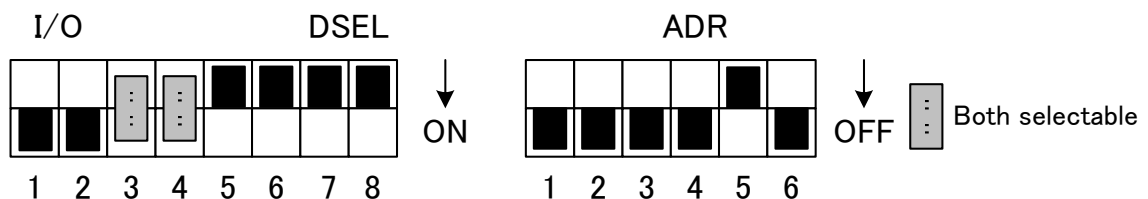

7. Warranty

If it fails during normal use, we will repair it free of charge as described in this warranty as below.

- 1) During the warranty period which is one year from the date of purchase, we will repair it free of charge in case of malfunction in accordance with instruction manual.
- 2) It will be charged for extra in the following case, even during warranty period.
 - Incorrect usage of failure or damage caused by carelessness,
 - Failure or damage caused by improper repair or remodeling.
 - Failure or damage caused by external factors such as fire, earthquake, other natural disasters, abnormal voltage and so on.
 - Change of power supply and voltage.
- 3) This warranty provision is effective only in Japan.